

SPINDLE VALVES

With these robust and low-dead-space valves, the product comes into contact only with the extremely corrosion-resistant materials borosilicate glass 3.3 and PTFE. They are therefore suitable for almost universal use in Miniplant technology.

The low leakage rate and impermeability of the spindle insert are special characteristics of this valve design. Impermeability is achieved through O-rings that are pressed onto an adjustable adapter sleeve and guided into a very precisely produced valve sleeve made of borosilicate glass 3.3. The top parts of the spindle valves can be replaced.

All spindle valves can be equipped with a pneumatic drive. The connection for the pneumatic hose is 6 mm.

 Spindle valves with a PTFE stamp are limited to product temperatures of 180°C. Top parts free of nonferrous metal are also available.



SPINDLE VALVES

DN/GL	L	H	H1	Type	Reference
GL18	125	143	111	A	M-SPVGL18
DN15/GL18	125	143	111	B	M-SPV15/GL18
DN15/GL25	125	143	111	B	M-SPV15/GL25
DN25/GL25	175	177	139	B	M-SPV25/GL25
GL18/DN15	125	143	111	C	M-SPVGL18/15
GL25/DN15	125	143	111	C	M-SPVGL25/15
GL25/DN25	175	177	139	C	M-SPVGL25/25
DN15	125	143	111	D	M-SPV15
DN25	175	177	139	D	M-SPV25

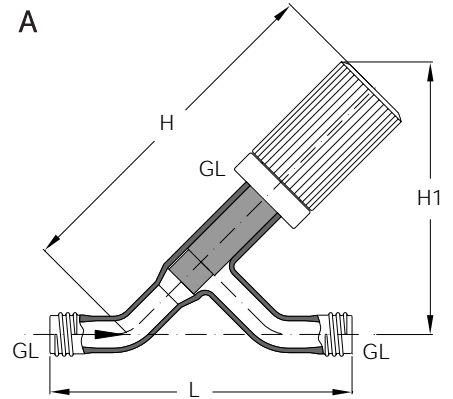

B

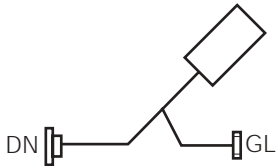

C

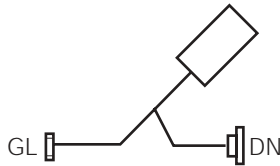

D

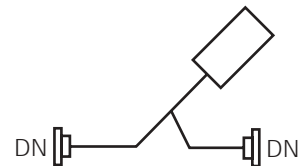

SPINDLE VALVES WITH PNEUMATICAL ACTUATOR

DN/GL	L	H	H1	Type	Reference
GL18	125	163	128	A	M-SPVPG18
DN15/GL18	125	163	128	B	M-SPVP15/GL18
DN15/GL25	125	163	128	B	M-SPVP15/GL25
DN25/GL25	175	207	160	B	M-SPVP25/GL25
GL18/DN15	125	163	128	C	M-SPVPG18/15
DN25/GL15	125	163	128	C	M-SPVPG25/15
GL25/DN25	175	207	160	C	M-SPVPG25/25
DN15	125	163	128	D	M-SPVP15
DN25	175	207	160	D	M-SPVP25

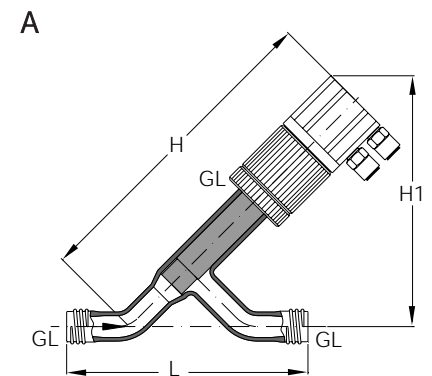

B

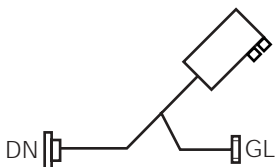

C

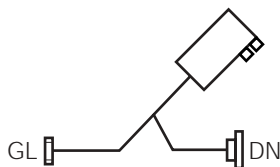

D

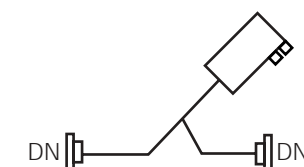

SPINDLE VALVES

DN/GL	L	H	Type	Reference
GL18	50	101	A	M-SPVEGL18
DN15/GL18	50	101	B	M-SPVE15/GL18
DN15/GL25	50	101	B	M-SPVE15/GL25
DN25/GL25	100	121	B	M-SPVE25/GL25
GL18/DN15	50	101	C	M-SPVEGL18/15
GL25/DN15	50	101	C	M-SPVEGL25/15
GL25/DN25	100	121	C	M-SPVEGL25/25
DN15	50	101	D	M-SPVE15
DN25	100	121	D	M-SPVE25

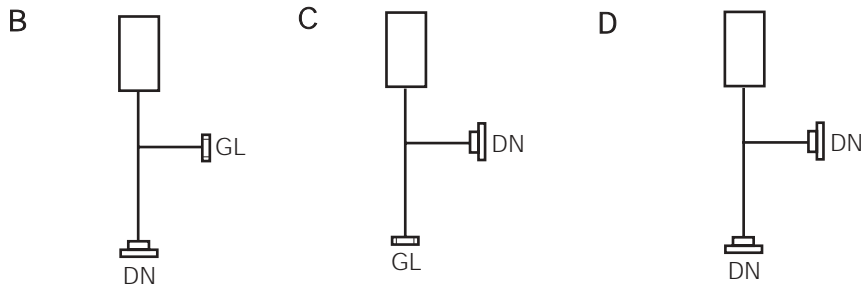
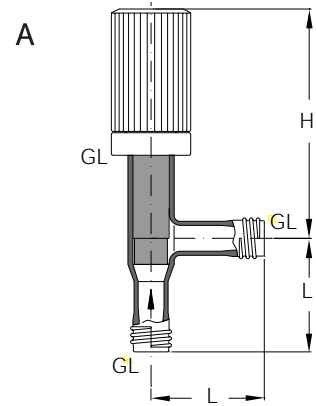

SPINDLE VALVES WITH PNEUMATICAL ACTUATOR

DN/GL	L	H	Type	Reference
GL18	50	121	A	M-SPVEPGL18
DN15/GL18	50	121	B	M-SPVEP15/GL18
DN15/GL25	50	121	B	M-SPVEP15/GL25
DN25/GL25	75	150	B	M-SPVEP25/GL25
GL18/DN15	50	121	C	M-SPVEPGL18/15
GL25/DN15	50	121	C	M-SPVEPGL25/15
GL25/DN25	75	150	C	M-SPVEPGL25/25
DN15	50	121	D	M-SPVEP15
DN25	75	150	D	M-SPVEP25

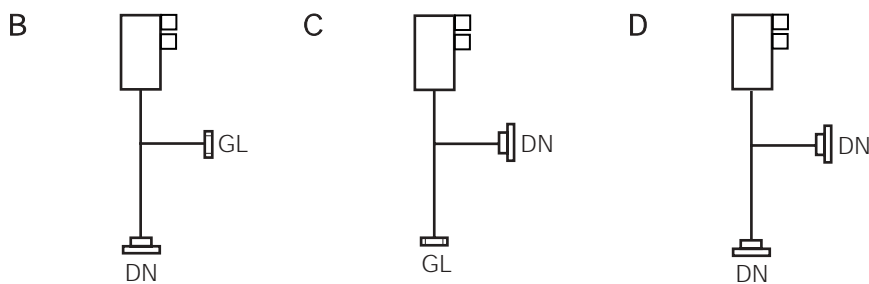
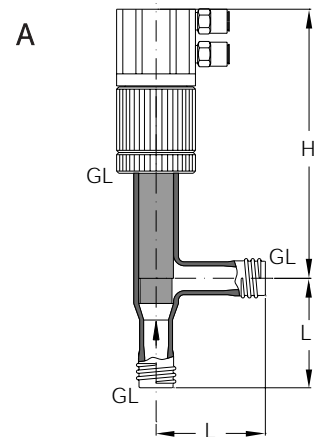

THREE WAY VALVES

DN/GL	L	L1	H	Type	Reference
DN15	50	100	151	A (manual)	M-SPVW15
DN25	100	125	183	A (manual)	M-SPVW25
DN15	50	100	171	B (pneumatical)	M-SPVWP15
DN25	100	125	213	B (pneumatical)	M-SPVWP25

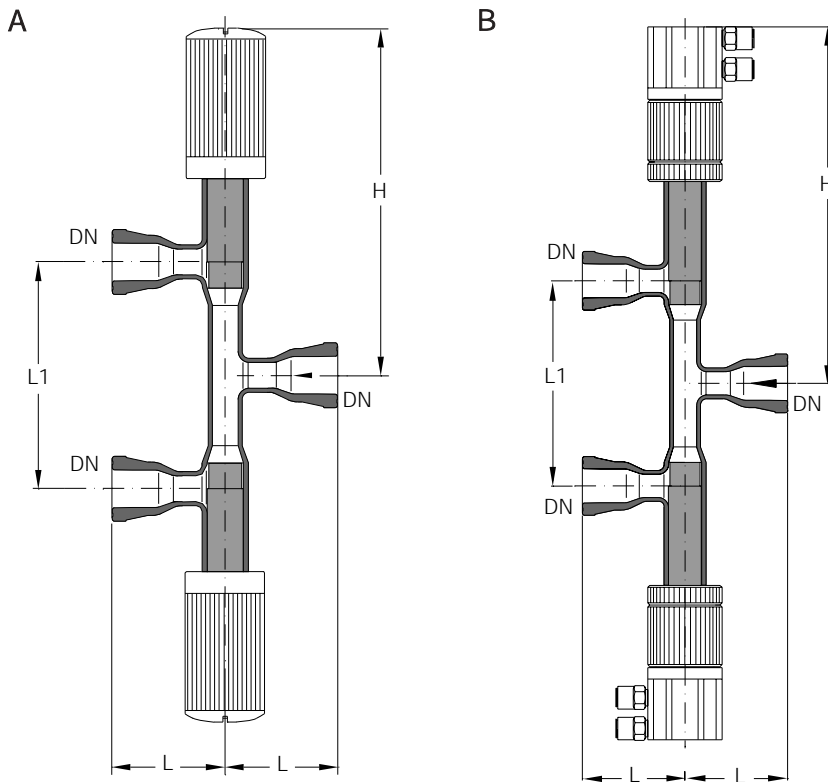

SPINDLE VALVE TOP PART

All top parts of the spindle valves are replaceable and assigned to the valve bodies via the connection thread. For special applications, you can obtain designs free of nonferrous metal (...BF).

GL	D2	H	Reference
18	8,6	79	M-OSPV6
25	14,5	115	M-OSPV10
32	20,5	139	M-OSPV15
18	8,6	79	M-OSPV6BF
25	14,5	115	M-OSPV10BF
32	20,5	139	M-OSPV15BF

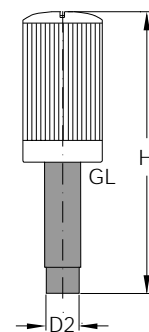

GLASS NEEDLE VALVE

These valves can be used everywhere that high demands are placed on dosage accuracy.

DN/GL	L	H	Type	Reference
GL18	50	70	A	M-GNVGL18
DN15	50	70	B	M-GNV15

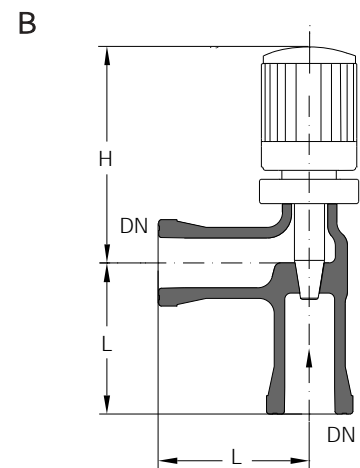
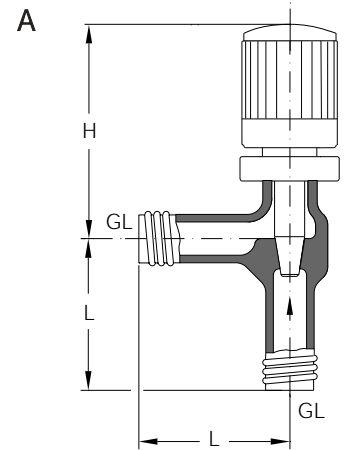

BOTTOM OUTLET VALVES WITH BELLOWS

Bottom outlet valves with bellows are used for vessels with volumes of 10 liters or more. The seal is in the vessel bottom and is self-adjusting. As a result, low and changing temperatures are possible. The bottom geometry and bellows together provide a low-dead-space combination that meets the highest purity requirements.

Besides the standard bottom outlet valves (A), versions are also available with an integrated overtight lock (B). Due to the smooth surface, all glass fittings close with a very low contact pressure. To protect against incorrect operation, the version with overtight lock can be used.

For vessels <10 l, spindle outlet valves are used (M-OBAS...).

 The fittings BAMD25 and BAMDT25 are used for vessels with jacket.

DN	d	L	L1	Type	Reference
25	27	260	115	A	BASD25
25	27	310	115	A	BAMD25
25	27	265	120	B	BASDT25
25	27	315	120	B	BAMDT25

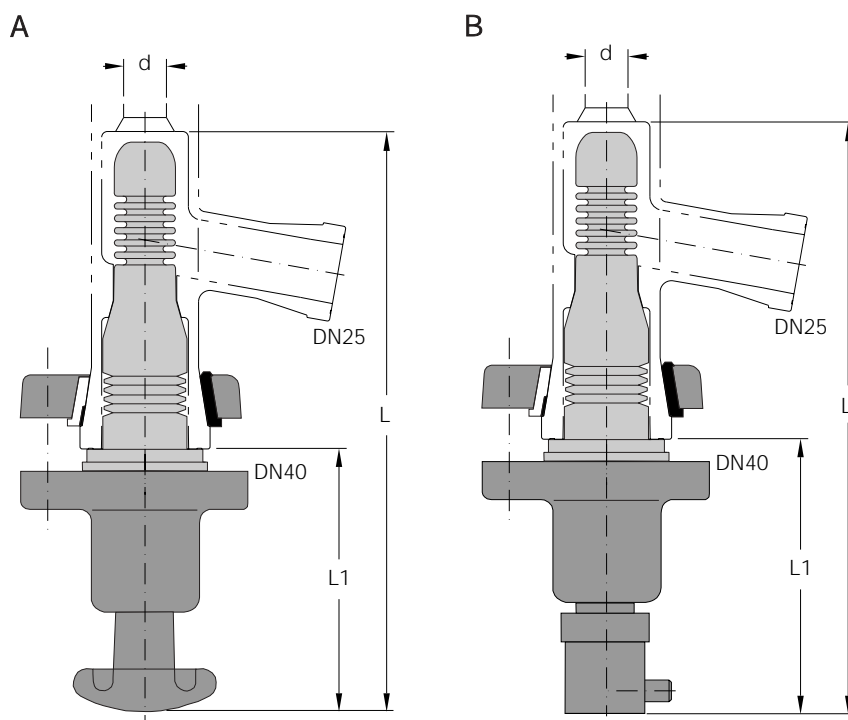

BOTTOM OUTLET VALVE SPINDLE

These robust and replaceable valve top parts combined with the valve bodies melted onto reaction vessels result in low-dead-space, highly vacuum-resistant bottom outlet valves. Almost universal use is ensured since the product only comes into contact with the highly corrosion-resistant materials PTFE and borosilicate glass 3.3.

The low leakage rate is achieved through an additional installed compression spring, which compensates for the shrinking of the valve cone during a cooling-off process.



The bottom outlet valves are assigned to the reaction vessels based on the connection thread. The specified length is measured from the glass thread end.

GL	D2	H	Reference
25	12,5	190	M-OBAS10
32	16,5	225	M-OBAS15

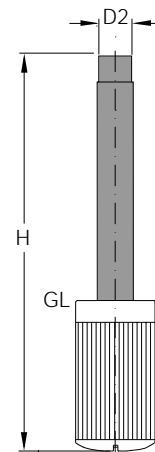

LOADING VALVES

They are used to set a constant pressure or for artificial pressure build-up. All parts in contact with the product are made of the highly corrosion-resistant materials PTFE and borosilicate glass 3.3. They are set at the factory to 0.3 bar and can be set to other pressures if desired.



Pressure holding valves must not be used as safety valves.

DN	GL	L	L1	L2	Reference
15	18	220	135	59	M-PVF15

